

DIAMOND DRYERS

POWERFUL, BEAUTIFUL, TOUGH

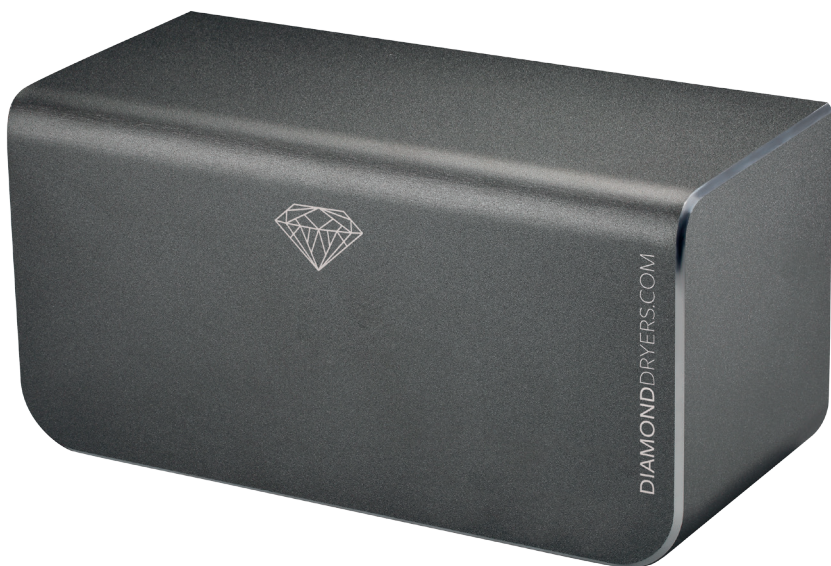

Installation Manual

Surface Mounted High Speed Hand Dryer

OPERATING INSTRUCTIONS AND PARTS MANUAL

TECHNICAL SPECIFICATIONS

Item Category	Performance Data
Operating Voltage	AC 220~240 V, 50/60 Hz, 380 W
Standby Power	≤0.5 W
Warm Air Speed Output	100 m/s
Motor Type	Brushless DC Motor, 26,500 RPM
Sensor Type	Auto Infrared touch free operation
Sensor Range	45° 5 ~ 12 mm
Timing Protection	30 seconds auto shut off
Drying Time	10 ~ 12 sec
Drip Proof	IPX3
Isolation	CLASS 1
Unit Size	272mm x 136mm x 123mm

IMPORTANT SAFETY INSTRUCTIONS



WARNING – TO REDUCE THE RISK OF FIRE, ELECTRIC SHOCK, OR INJURY TO PERSONS OBSERVE THE FOLLOWING:

- Use this unit only in the manner intended by the manufacturer. Manufacturer is not responsible for damages caused by misuses or defective installations.
- The instructions contained within the installation Template enclosed must be followed carefully when installing this unit. Failure to accurately follow the instructions may result in the incorrect operation of this unit, damage to property and/or personal injury.
- Installation work and electrical wiring must be done by qualified person(s) in accordance with all applicable codes and standards, including fire-rated construction.
- When cutting or drilling into wall or ceiling, do not damage electrical wiring and other hidden utilities.
- This unit must be powered by a dedicated circuit branch protected by a circuit breaker with the appropriate rating. Circuit cable must be fit current consumption for this unit.
- This unit has been designed for indoor use only, protected from water, sun and extreme temperatures, do not use it outdoors or close to moisture and heat generators.
- This unit can only be revised, maintained, repaired and removed by qualified person(s). If the unit stops and works strangely, contact your regional dealer or contractor.
- This appliance can be used by children aged from 8 years and above and persons with reduced physical, sensory or mental capabilities or lack of experience and knowledge if they have been given supervision or instruction concerning use of the appliance in a safe way and understand the hazards involved. Do not allow children to play with the appliance or carry out cleaning and user maintenance on this hand dryer.
- If the supply cord is damaged, it must be replaced by the manufacturer, its service agent or similarly qualified persons in order to avoid a hazard.

UNPACKING / STANDARD ACCESSORIES

1. Remove all packing material. Recycling is recommended.
2. Carefully remove the hand dryer from the shipping carton, using care not to drop the appliance.
3. Use caution when removing the casing. The casing may have sharp edges/ corners which may cut or cause harm.
4. Inspect carefully for any damage that may have occurred during transit. Check for any loose, missing or damaged parts. If the hand dryer is damaged, promptly inform the shipper or dealer where you purchased it.

Standard items included with the hand dryer are:

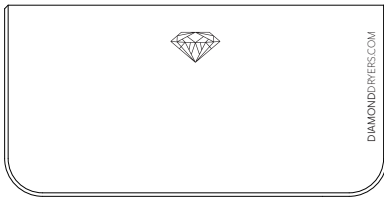

Main Unit



Service Tool

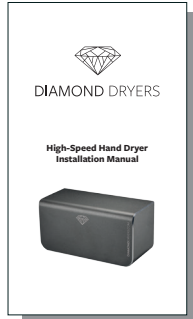

Manual



Wall Mounting anchors



Flat cable clamp & Screw

INSTALLATION

CAUTION

- Make sure power supply breaker is switched off.
- All electrical installation and repair work should be carried out by a qualified electrician or local service Engineer in accordance with current local codes or regulations.
- Check that the electrical supply corresponds to that shown on the rating plate. If the unit is connected to any electrical supply other than stated on the rating plate of the unit, permanent damage or unsafe operation of the unit may result.
- The unit must be mounted on a flat vertical wall capable of supporting the full weight of the unit.
- Do not use the backplate as a guide when drilling. Ensure no pipe work (gas, water, air) or electrical cables, wires or ductwork are located directly behind the drilling/mounting area.

1. UNPACKING

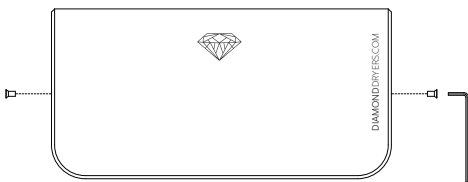

1.1 Place the main cover on a cloth to avoid marking its surface.

1.2 Remove the (2) security screws from the main body, using the service tool provided. Store safely.

1.3 Lift the front cover off the main body.

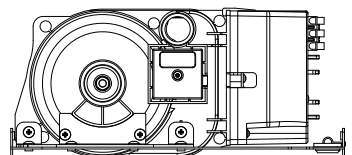
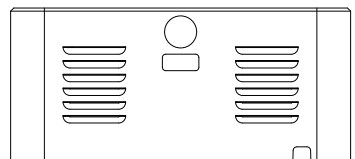

CAUTION: Before installation decide if the cable entry is to be from the rear or the above. Follow the relevant instructions. Do not use the backplate as a guide when drilling.

2. POSITIONING

2.1 Mark the location on the wall with a pencil. Use the Backplate to mark the locations for the four fixing points (**2**).

2.2. Pre-drill the wall in the marked locations using a 5/16 (8mm) drill, inset the plastic anchors and tap flush to the wall (**3**).

2.3 Fix the backplate to the wall. Screw to the wall and secure with the appropriate fitting.

3. INSTALLING THE POWER CABLE & CONNECTION TERMINAL BLOCK

WARNING: ENSURE POWER IS NOT CONNECTED

3.1 Pull the cable through the grommet. Ensure the cable is long enough to route correctly through the backplate to the terminal block.

3.2 The cable must sit in the dedicated channel.

3.3 As shown, connect cable to terminal block (**4**).

3.4 Screw in terminal block.

3.5 Fix the cable clamp with screw in the backplate.

CAUTION: Connect the ground wire to the terminal block marked '⊕'.

Do not over-tighten and crush the power cable.

4. ATTACHING MAIN BODY

4.1 Close the main cover of the backplate (**5**).

4.2 Insert and tighten the (2) security screws into the side of the main body with the service tool as illustrated below.

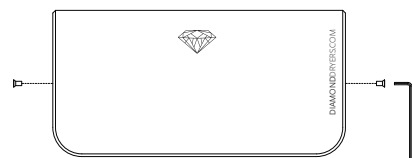

4.3 Turn power on.

4.4 Test unit for correct operation.

Recommended height measurements from the floor to top screws (**1**).

Adult male	1300mm
Adult female	1265mm
Children 5-8 years old	928mm
Children 8-11 years old	1028mm
Children 11-14 years old	1108mm
Wheelchair user	1050mm

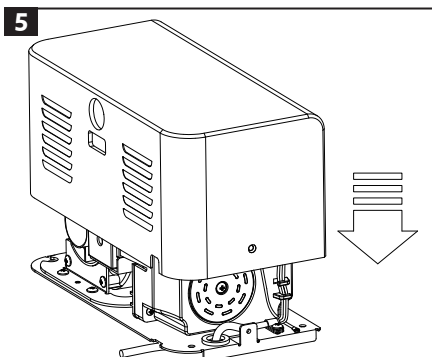
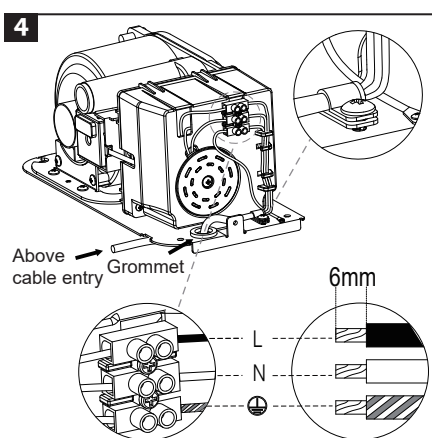
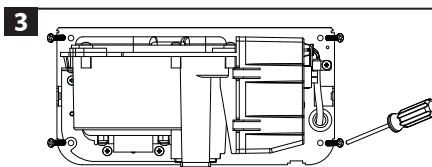
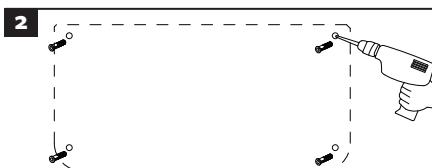
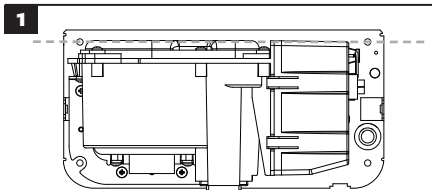

OPERATION

1. No touch operation
2. Shake excess water from hands.
3. Place hands under the outlet to start operation.
4. Slowly move hands back and forth through the hand dryer.
5. Start operation the blue LED lights.
6. Stop automatically after hands are removed.

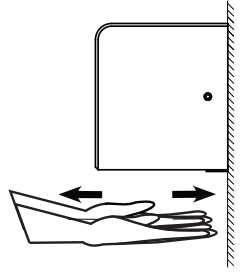

If there is an electrical or motor problem a blue LED will blink when hands through the hand dryer

MAINTENANCE

REGULAR MAINTENANCE

Regularly clean the outer casing use a soft, damp cloth to gently wipe away any dirt.

CAUTION: Never use abrasives or chemicals to clean the cover. Do not soak.

PERIODICAL DEEP CLEAN

Cleaning and maintenance must be performed by qualified electrical personnel.

1. Disconnect the electrical supply.
2. Use the service tool or security hex driver to remove the two cover security screws.
3. Remove the cover.
4. Clean all dust and lint from the interior of the hand dryer.
5. Replace the cover.
6. Wipe the cover with a damp cloth.

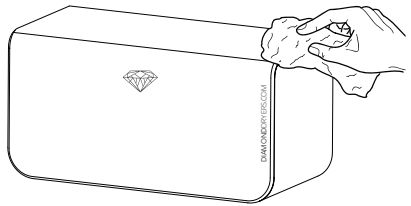

CAUTION: Do not over tighten the screws.